

Introduction

Thank you for purchasing the FrSky Horus X12S-ISR digital telemetry radio system. In order to make the best use of your system and to fly safely, please read this manual carefully. If you have any difficulties while using your system, please consult the manual, your hobby dealer, or FrSky technical support.

Due to unforeseen changes in production, the information contained in this manual is subject to change without notice.

Meanings of Special Markings

Pay special attention to safety where indicated by the following marks:

- ⚠ DANGER-** Procedures which may lead to dangerous conditions and cause death/serious injury if not carried out properly.
- ⚠ WARNING-** Procedures which may lead to a dangerous condition or cause death or serious injury to the user if not carried out properly or procedures where the probability of superficial injury or physical damage is high.
- ⚠ CAUTION-** Procedures where the possibility of serious injury to the user is small, but there is a danger of injury, or physical damage, if not carried out properly.

ⓘ = Mandatory ⓧ = Prohibited

⚠ Warning: Always keep electrical components away from small children.

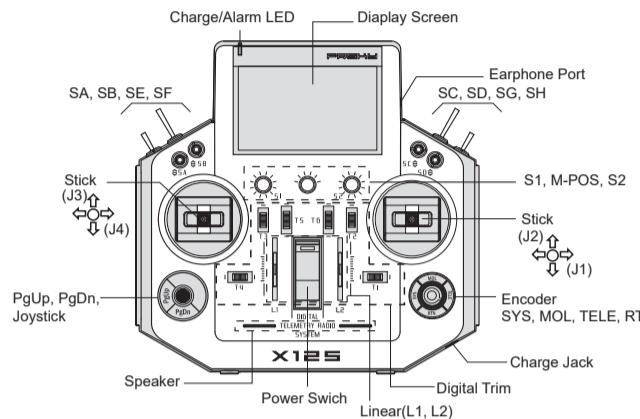

Overview

(Switch Default Settings)

- SA: 3 positions, Short Lever
- SB: 3 positions, Long Lever
- SC: 3 positions, Long Lever
- SD: 3 positions, Short Lever
- SE: 3 positions, Short Lever
- SF: 2 positions, Long Lever
- SG: 3 positions, Short Lever
- SH: 2 positions, Momentary; Long Lever

You can choose the Switch and define its positions in the Input and Output Map screen.

Infinity 24 Antenna

Recommended 2.4GHz optional high-gain antenna for achieving higher performance and further range.

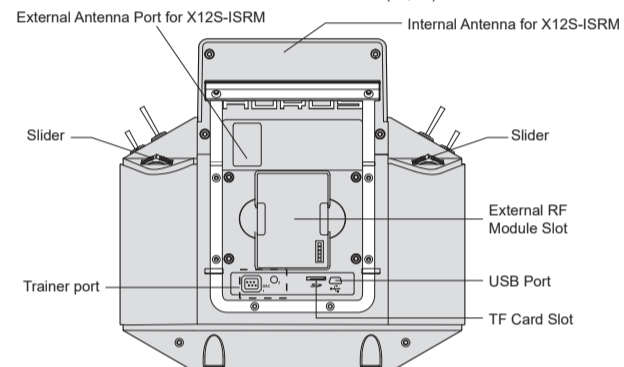
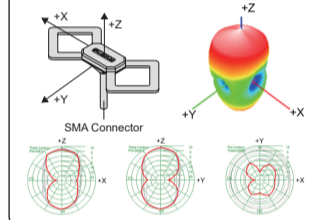

⚠ Cautions on handling antenna of External Module

- ⓧ Do not touch the antenna during operation. Doing so could interfere with transmission, causing a crash.
- ⓧ Do not carry the transmitter by the antenna. The antenna wire could break and prevent transmission.
- ⓧ Do not pull the antenna forcefully. The antenna wire could break and prevent transmission.

Specifications

- Model Name: Horus X12S-ISR
- Number of Channels: 16 channels (Up to 32 channels)
- Operating Voltage: DC9.6V
- Operating Temperature: -10~60°C
- Industrial screen: high resolution TFT (480*272), readable outdoor
- Compatibility: ACCST D16 and ACCESS receivers
- 16M Flash
- * SD card is not supplied with X12S-ISR Horus, please purchase separately.

Features

- Supports FrSky ETHOS Operating System
- Audio Speech Outputs (values, alarms, settings, etc.)
- Full Telemetry & Real-time Data Logging
- Antenna Detection & SWR Warning
- Integrated GPS Module & 6-Axis Sensor (3-Axis Gyro & 3-Axis Accelerator)
- All CNC 6 Ball Bearings Gimbals with Accuracy Hall-Sensor & Extensible Stick Ends
- Safe Power Switch with Integrated Strap Base
- Two Types Trainer Ports
- Built-in PARA Wireless Trainer System
- 6 Position Encoder for Easier Flight Modes Switch
- MP3 Audio Player
- Industrial High Resolution TFT Screen Readable Outdoor
- Internal and External Antenna Switchable

⚠ Notes and Warnings for Battery & Charger

- ⓧ The eight-cell NiMH battery is for use only in your Horus X12S-ISR.
- ⓧ Be sure to use the built-in battery charger to charge the battery.
- ⓧ Be careful not to drop the battery.
- ⓧ Don't pull the battery wires as this could produce, short-circuits and cause the battery to explode.
- ⓧ Do not remove the battery from the Horus X12S-ISR transmitter while the voltage warning is blinking as this could cause internal settings and memories to be destroyed.
- ⓧ Be sure to turn off the Horus X12S-ISR before charging the battery.
- ⓧ The Power Indicator LED will be on during charging, and be off after the charging is finished.

ETHOS Operating System

Create the model

Step 1: First go to System Settings, then select model select click the plus sign to select model type.

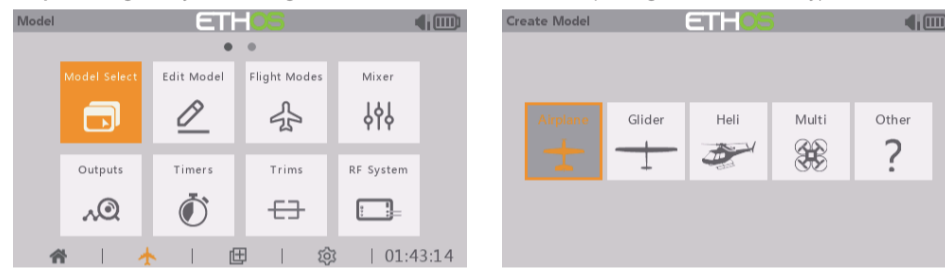

Step 2: Configure the model channel and create the model name.

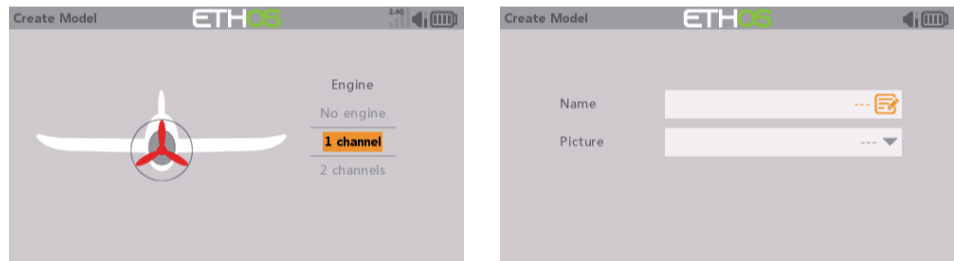

Model Setup Procedure-Internal Module

Step 1: Use the navigation keys to enter the RF system menu.



Choose the INT MODULE. Then turn ON INTERNAL RF, select the OUTSIDE or INSIDE ANTENNA. Set the Mode for Horus X12S-ISR internal RF corresponding to your receiver (ACCESS, ACCST D16).

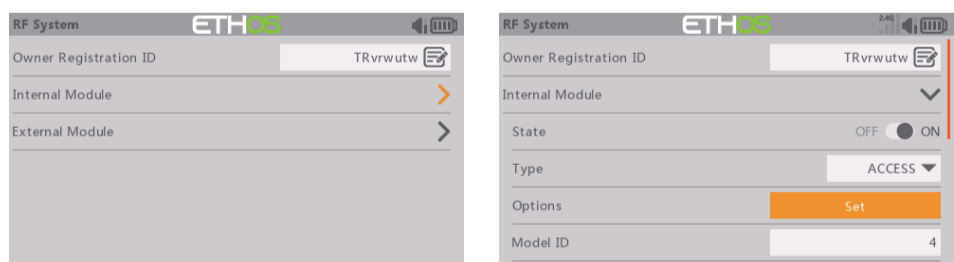

Step 2: Set the Channel Range

The ISR RF module supports 24 channels. the channel range is configurable, and it needs to be double checked before use.



Step 3: Set the Receiver Number

The system will assign you the receiver a number automatically, when you create a new model, and this can be easily changed. The range of the Model ID is 00-63, with the default number being 01. Once the receiver is set to the desired number and is bound to the Horus X12S-ISR, the bind procedure will not need to be repeated unless the receiver number is changed. At this point, set the receiving number to your preferred number and repeat the binding operation.

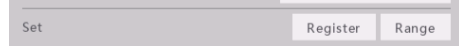

Step 4: Registration

In ACCESS model, select the STATE [Register] into Registration status on radio side. Then Press the F/S button and power on your receiver, and select the "RX Name XX" and [REGISTER] to complete the Registration process then power down the receiver.

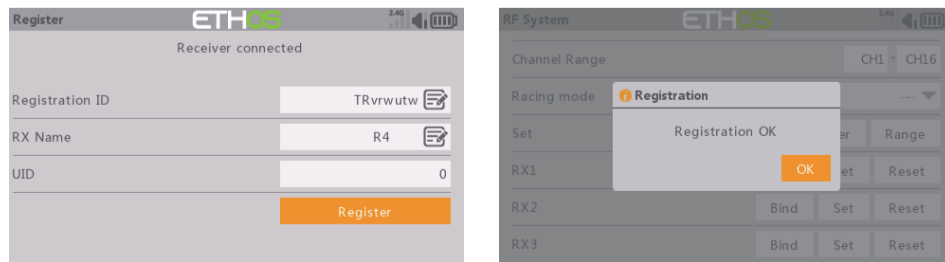

Step 5: Automatic binding (Smart Match)

Move the cursor to Rx1[BIND], and select it, power your receiver, select the RX, and complete the process, the system will confirm "Bind succeed". (Pressing the "F/S" button is not required in ACCESS to Bind. Please the receivers manual for details).

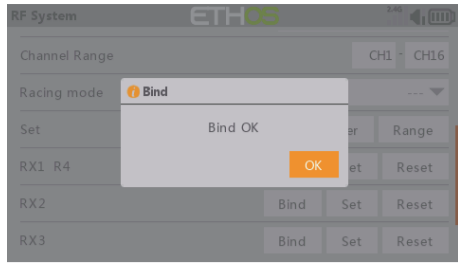
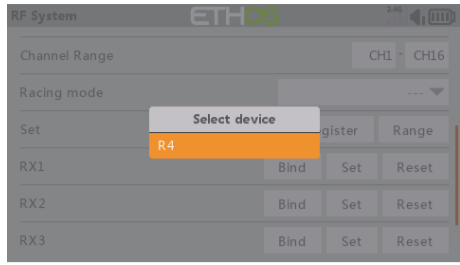

Step 6: Set Failsafe mode

There are 3 failsafe modes when enable: No Pulse, Hold, Custom.



- No Pulse: on loss of signal the receiver produces no pulses on any channel. To use this type, select it in the menu and wait 9 seconds for the failsafe to take effect.
- Hold: the receiver continues to output the last positions before signal was lost. To use this type, select it in the menu and wait 9 seconds for the failsafe to take effect.
- Custom: pre-set to required positions on lost signal. Move the cursor to the failsafe mode of channel and press Encoder, then choose the Custom mode. Move the cursor to the channel you want to set failsafe on, and press Encoder.

Then rotate the Encoder to set your failsafe for each channel and short press Encoder to finish the setting. Wait 9 seconds before the failsafe takes effect.

Notice:

- When failsafe is disabled on Horus X12S-ISRM side, the failsafe set on receiver side will be used.
- SBUS port does not support the No Pulse failsafe mode and always outputs. Set "Hold" or "Custom" for SBUS port.

Step 7: Range

Range refers to Horus X12S-ISRM range check mode. A pre-flight range check should be done before each flying session. Move the cursor to "STATE", scroll the Encoder to select "RANGE" mode and press Encoder. In range check mode, the effective distance will be decreased to 1/30. Press the Encoder again, turn to normal state.

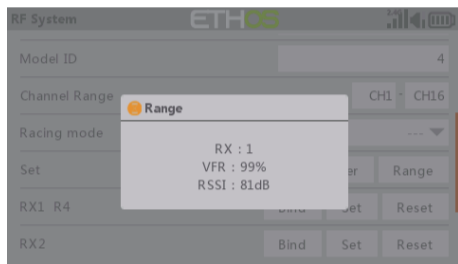
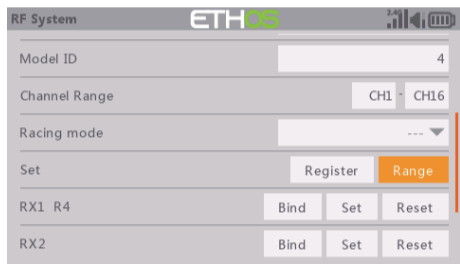

Model Setup for Horus X12S-ISRM External RF Module

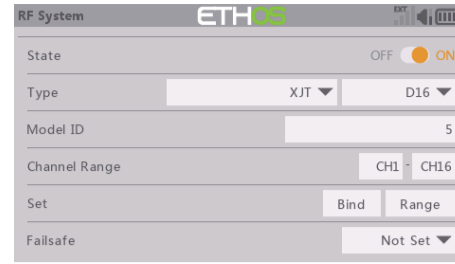

The external RF module can be powered on or off by software. The setup process is the same as that for the internal RF. External modules should be closed when not in use.

FCC Statement

Changes or modifications not expressly approved by the party responsible for compliance could void the user's authority to operate the equipment.

NOTE: This equipment has been tested and found to comply with the limits for a Class B digital device, pursuant to Part 15 of the FCC Rules. These limits are designed to provide reasonable protection against harmful interference in a residential installation.

This equipment generates uses and can radiate radio frequency energy and, if not installed and used in accordance with the instructions, may cause harmful interference to radio communications.

Make sure you set the country code to your corresponding country to match the regulations.

However, there is no guarantee that interference will not occur in a particular installation. If this equipment does cause harmful interference to radio or television reception, which can be determined by turning the equipment off and on, the user is encouraged to try to correct the interference by one or more of the following measures:

- Reorient or relocate the receiving antenna.
- Increase the separation between the equipment and receiver.
- Connect the equipment into an outlet on a circuit different from that to which the receiver is connected.
- Consult the dealer or an experienced radio/TV technician for help.

RF warning statement:

The device has been evaluated to meet general RF exposure requirement. The device can be used in portable exposure condition without restriction.

CE

The product may be used freely in these countries: Germany, Italy, Spain, Belgium, Netherlands, Portugal, Greece, Ireland, Denmark, Luxembourg, Austria, Finland, Sweden, Norway, Switzerland, France and Iceland.

FLYING SAFETY

⚠ Warning:

To ensure the safety of yourself and others, please observe the following precautions.

Ⓢ **Have regular maintenance performed.** Although your Horus X12S-ISRM protects the model memories with non-volatile EEPROM memory (which does not require periodic replacement) and of a battery, it still should have regular check-ups for wear and tear. We recommend sending your system to your FrSky Service Center annually during your non-flying-season for a complete check-up and service.

Battery

Ⓢ **Charge the batteries!** Using the standard Horus battery and charger, always recharge the transmitter and receiver batteries for at least 8 hours before each flying session. A low battery will soon die, causing loss of control and a crash. When you begin your flying session, reset your transmitter's built-in timer, and during the session pay attention to the duration of usage. Also, if your model uses a separate receiver battery, make sure it is fully charged before each flying session.

Ⓢ **Stop flying long before your batteries become low on charge. Do not rely on your radio's low battery warning systems, intended only as a precaution, to tell you when to recharge. Always check your transmitter and receiver batteries prior to each flight.**

Where to Fly

We recommend that you fly at a recognized model airplane flying field. You can find model clubs and fields by asking your nearest hobby dealer.

Ⓢ **Always pay particular attention to the flying field's rules**, as well as the presence and location of spectators, the wind direction, and any obstacles on the field. Be very careful flying in areas near power lines, tall buildings, or communication facilities as there may be radio interference in their vicinity.

At the flying field

1. To prevent possible damage to your radio gear, turn the power switches on and off in the proper sequence:
 1. Pull throttle stick to idle position, or otherwise disarm your motor/engine.
 2. Turn on the transmitter power and allow your transmitter to reach its home screen.
 3. Confirm the proper model memory has been selected.
 4. Turn on your receiver power.
5. Test all controls. If a servo operates abnormally, don't attempt to fly until you determine the cause of the problem. (For PCM systems only: Test to ensure that the Failsafe settings are correct by waiting at least 2 minutes after adjusting then, turning the transmitter off and confirming the proper surface/throttle movements. Turn the transmitter back on.)
6. Start your engine.
7. Complete a full range check.
8. After flying, bring the throttle stick to idle position, engage any kill switches or otherwise disarm your motor/engine.

If you do not turn on your system on and off in this order, you may damage your servos or control surfaces, flood your engine, or in the case of electric-powered or gasoline-powered models, the engine may unexpectedly turn on and cause a severe injury.

Ⓢ **Make sure your transmitter can't tip it over.** If it is knocked over, the throttle stick may be accidentally moved, causing the engine to speed up. Also, damage to your transmitter may occur.

Ⓢ In order to maintain complete control of your aircraft it is important that it remains visible at all times. Flying behind large objects such as buildings, grain bins, etc. must be avoided. Doing so may interrupt the radio frequency link to the model, resulting in loss of control.

Ⓢ Do not grasp the transmitter's antenna during flight. Doing so may degrade the quality of the radio frequency transmission and could result in loss of control.

Ⓢ As with all radio frequency transmissions, the strongest area of signal transmission is from the sides of the transmitter's antenna. As such, the antenna should not be pointed directly at the model. If your flying style creates this situation, easily move the antenna to correct this situation

Ⓢ **Before taxiing, be sure to extend the transmitter antenna to its full length.**

A collapsed antenna will reduce your flying range and cause a loss of control. It is a good idea to avoid pointing the transmitter antenna directly at the model, since the signal is weakest in that direction.

Ⓢ **Don't fly in the rain!** Water or moisture may enter the transmitter through the antenna or stick openings and cause erratic operation or loss of control. If you must fly in wet weather during a contest, be sure to cover your transmitter with a plastic bag or waterproof barrier. Never fly if lightning is expected.

Nickel-metal hydride Battery Safety and Handling instructions

IMPORTANT! The Nickel-Metal Hydride battery (NiMH) batteries included in the Horus X12S-ISRM transmitter are not to be confused with Lithium-Polymer (LiPo) batteries, or any other type of rechargeable battery (including NiCd and LiFe). NiMH batteries require special charging criteria different than other rechargeable batteries. Use only the FrSky transmitter charger included with this set for, or other chargers approved by FrSky, to charge the NiMH batteries in the HORUS X12S-ISRM transmitter.

It's important to understand the operating characteristics of Nickel-Metal Hydride battery (NiMH). Read the specifications printed on the label of your NiMH battery and charger prior to use. Failure to follow the these precautions can quickly result in severe, permanent damage to the battery and its surroundings and possibly result in a FIRE!

IMPORTANT PRECAUTIONS

- Ⓢ Do not leave a NiMH battery unattended at any time while being charged or discharged.
- Ⓢ Do not attempt to charge NiMH batteries with a charger that is NOT designed for NiMH batteries, as permanent damage to the battery and charger could result.
- Ⓢ Always charge NiMH batteries in a fireproof location. Do not charge or discharge NiMH batteries on carpet, a cluttered workbench, near paper, plastic, vinyl, leather or wood, or inside an R/C model or full-sized automobile! Monitor the charge area with a smoke or fire alarm.
- Ⓢ Do not charge NiMH batteries at currents greater than the "1C" rating of the battery ("C" equals the rated capacity of the battery).
- Ⓢ Do not allow NiMH cells to overheat at any time! Cells which reach greater than 140 degrees Fahrenheit (60°C) should be placed in a fireproof location.
- Ⓢ NiMH cells will not charge fully when too cold or show full charge.
- Ⓢ It is normal for the batteries to become warm during charging, but if the charger or battery becomes excessively hot disconnect the battery from the charger immediately!! Always inspect for potential damage any battery which has previously overheated for potential damage, and do not re-use if you suspect it has been damaged in any way.
- Ⓢ Do not use a NiMH battery if you suspect physical damage has occurred to the pack. Carefully inspect the battery for even the smallest of dents, cracks, splits, punctures or damage to the wiring and connectors. DO NOT allow the battery's internal electrolyte to get into eyes or on skin—wash affected areas immediately if they come in.

Updates

FrSky is continuously adding features and improvements to our radio systems. Updating (via the pre-installed MicroSD card in Horus X12S-ISRM TF Card Slot) is easy and free. To get the most from your new transmitter, please check the download section of the FrSky website www.frsky-rc.com, for the latest update firmware and how-to guide.

Horus X12S-ISRM installed the FrSky FrTX operation system. Do not hesitate to contact FrSky if you have ideas and suggestions for current and future radio systems, or if you are willing to join the FrSky developing union to be part of the projects.

* The currently pre-installed firmware of Horus X12S-ISRM is FrSky FrTX firmware, developed and well tested by FrSky. The transmitter also support the open source firmware.