

Introduction

The Twin Lite PRO is a powerful RF module which enables ETHOS capable radios to bind to the TW series receivers and support the TW protocol's dual 2.4G frequencies simultaneously on the same receiver. The TW active-active protocol is different from the general active-standby redundancy solutions (where one receiver takes over signal control only when the other is in Failsafe mode), with the TW protocol, dual 2.4G frequency bands are active on the TW series module, and receiver at the same time.

The RF module has two 2.4G external antennas RF mounted to provide multi-directional and wider coverage for transmitting signals compared to a single antenna design. Taking advantage of these features, the Twin system can provide less latency and higher reliability at a faster data rate with confidence.

In addition to the TW mode, this module also supports ACCST D16 and ACCESS modes, this means users can benefit from a wide range of compatible receiver options to choose and bind to when building the RC model. The Twin Lite Pro module offers resilient RF power options up to 500mW, constructed with the CNC machined metal module shell that helps aid heat dissipation, this system can ensure a stable long-range control further around tens of kilometers under long working hours.

Overview

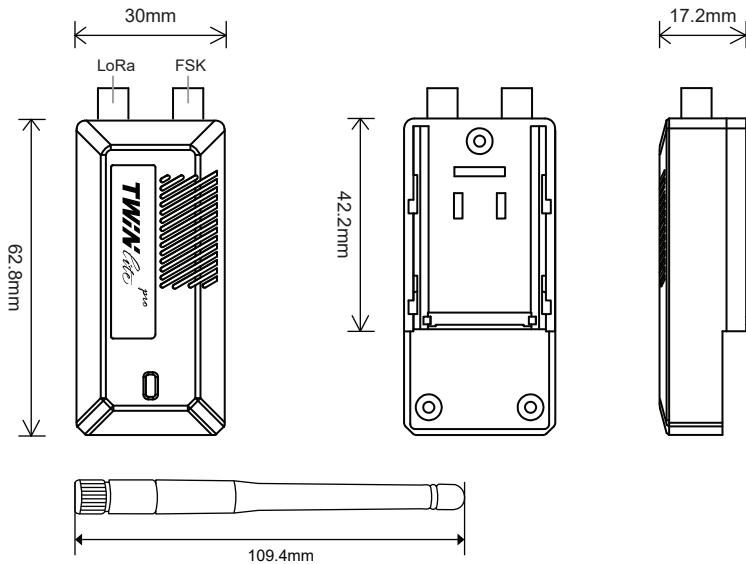

Specifications

- Dimension: 62.8*30*17.2mm (L*W*H)
- Weight: 36.8g (without antenna)
- Operating current: 84mA@100mW
- RF power: 10mW/25mW/100mW/200mW/500mW
- Supports multiple RF protocols: ACCST D16 / ACCESS / TW modes
- Antenna: 2* external 2.4G antenna

Features

- Less latency with more range and higher reliability at a faster data rate
- CNC machined metal module shell designed to aid heat dissipation
- Adjustable RF Power (Up to 500mW)
- Supports multiple RF protocols: ACCST D16 / ACCESS / TW modes
 - ◆ TW Mode (ETHOS Radios compatible)
 - Highly resilient RF module providing dual 2.4G signals working simultaneously
 - Long-range control (Tens of kilometers, range varies based on the RF Power settings.)
 - Low-latency (<4ms) supporting full telemetry

LED State

Mode	Green LED	Blue RED	Red LED
ACCST D16	OFF	ON	OFF
ACCESS	ON	OFF	OFF
ELRS	ON	ON	OFF
TW	ON	ON	ON

How to use the external RF module

STEP1: Enable RF Module

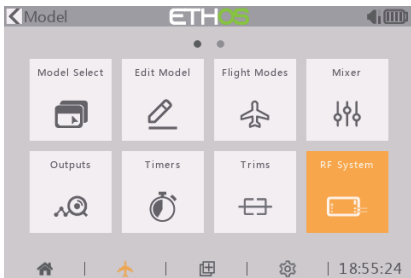

Enter the RF system menu by the touch-screen or use the navigation encoder key.



Choose the External Module.

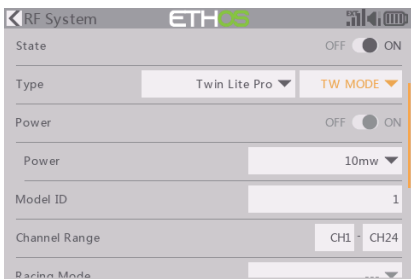

Then turn the state of External RF to On. Set the binding mode for the external RF module corresponding to the receiver (ACCST D16, ACCESS, ELRS, TW MODE).

STEP2: Channel Range Setting

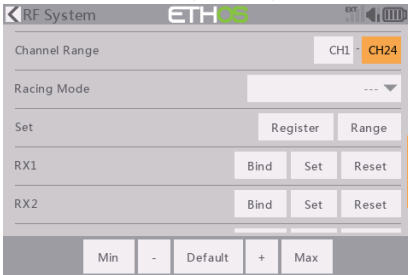

The TWIN Lite RF module supports 24 channels (1-8ch / 1-16ch / 1-24ch).

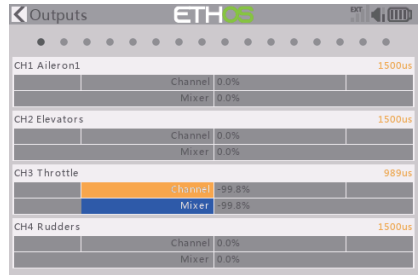

The channel range is configurable by pressing the channel bars, please also make sure of the channel configuration before using the module.

STEP3: Model ID Setting



The system assigns the receiver a number for the receiver (Model ID) automatically while creating a new model. (The Model ID can be set from 00 to 63, with the default ID being 1.)

STEP4: Registration

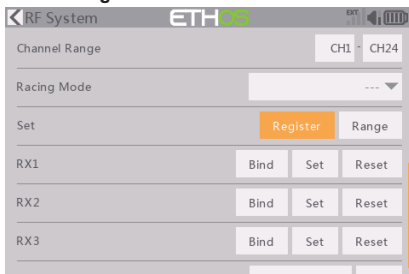

For TW Mode as an example, select the Set [Register] for getting the radio into Registration status in the RF System-External Module tool, then press the F/S button on the receiver and power the receiver on.

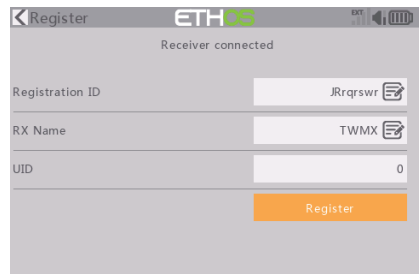

When the "RX Connected" page pops up, press the [REGISTER] to complete the Registration procedure and then power the receiver off. (The system automatically assigns the receiver a UID differently in the same model when you have several receivers to bind at the same time.)

STEP5: Automatic Binding (Smart Match)

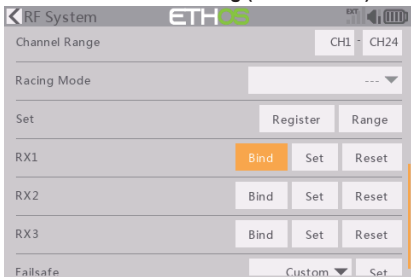

Move the cursor to RX1 [BIND], press it and repower the receiver.

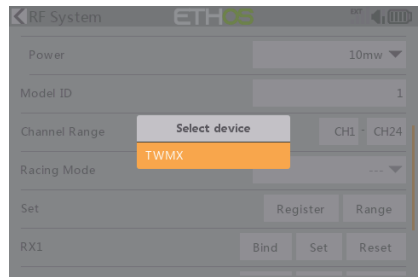

Click the RX to complete the binding after the receiver window pops up, the system will confirm "Bind succeed".

Reset: Registration procedure is not required to repeat anymore after the receiver is once registered even though the receiver is deleted. Pressing the [Reset] and repower the receiver can have the bound recovered.

STEP6: RF Power Setting

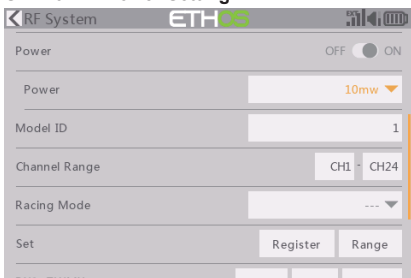

TWIN Lite Pro can offer multiple RF power options up to 500mW which can achieve a further controlling range.

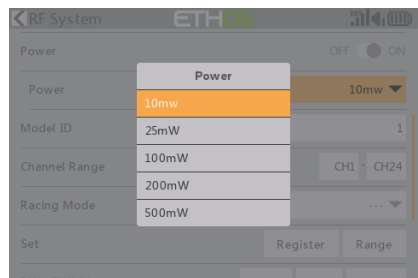

Open the Power menu bar and select the desired power level according to usage.

How to bind the receiver in the ELRS mode

STEP1:

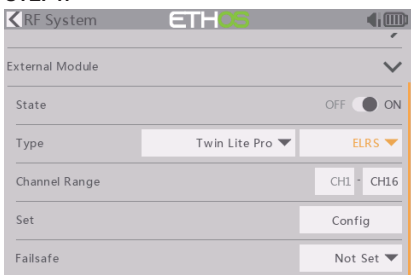

Change the binding mode to [ELRS] under the [TW Lite] module menu.

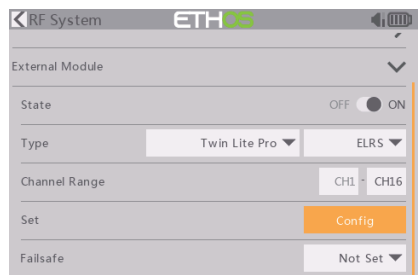

And press [Config] to enter the binding menu.

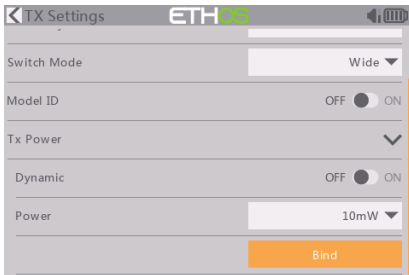
STEP2:

Power the ELRS receiver on and off 3 times, and the LED on the receiver will do a quick flash twice that indicating the receiver is in the binding mode.

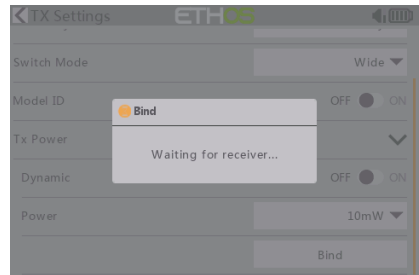

Click the [Bind] and if the receiver LED keeps lit, it means the receiver is bound successfully.

Range Check

A pre-flight range check should be done before every flight, in case the signal loss is caused by the reflection of the signal by the nearby metal fence or concrete, and the shading of the signal by buildings or trees during the actual flight. Under normal circumstances, in Range Check mode, the RSSI at 150m is about 45-50.

1. Place the model at least 60 cm (2 feet) above the non-metal contaminated ground (such as on a wooden bench). The receiving antenna should be in a vertical position.
2. Enter the ETHOS system, move to the "RF System", scroll the Encoder to select "RANGE" mode and press Encoder. In range check mode, the effective distance will be decreased to 1/30.

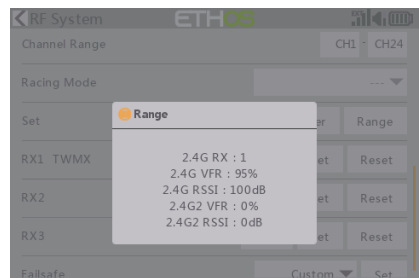
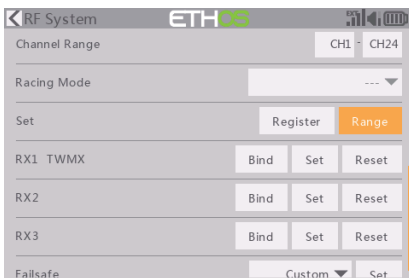
**How to set Failsafe**

There are 3 failsafe modes when the setting is enabled: No Pulse, Hold, and Custom mode.

- **No Pulses Mode:** On loss of signal, the receiver produces no pulses on any channel. To use this mode, select it in the menu and wait 9 seconds for the failsafe to take effect.
- **Hold Mode:** The receiver continues to output the last positions before the signal was lost. To use this mode, select it in the menu and wait 9 seconds for the failsafe to take effect.
- **Custom Mode:** Pre-set to required positions on the lost signal. Move the cursor to the failsafe mode of the channel and press Encoder, then choose the Custom mode. Move the cursor to the channel you want to set failsafe On and press Encoder. Then rotate the Encoder to set your failsafe for each channel and short-press the Encoder to finish the setting. Wait 9 seconds for the failsafe to take effect.

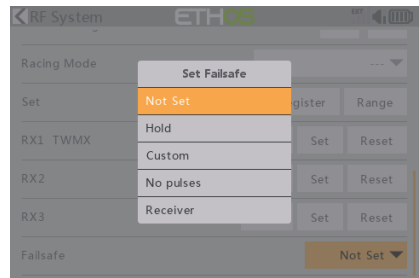
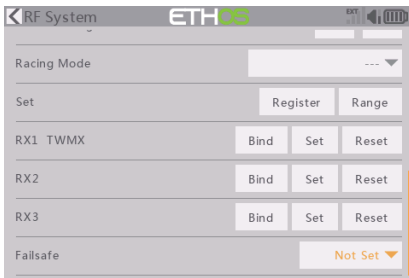
**Note:**

- If the failsafe is not set, the model will always work with the last working status before the signal is lost. That could cause potential damage.
- When the failsafe is disabled on the RF module side, the failsafe set on the receiver side will be applied.
- SBUS port does not support the failsafe setting in No Pulses mode and always outputs signal. Please set "Hold" or "Custom" mode for the SBUS port.

FrSky is continuously adding features and improvements to our products. To get the most from your product, please check the download section of the FrSky website www.frsky-rc.com for the latest update firmware and manuals